



M2LIFT

Vertical Platform Lift



OWNER'S MANUAL

(To Be Retained by Owner After Installation
by Authorized Savaria Dealer)

Part No. 001103
15-m02-2019

IMPORTANT

Ensure that only an authorized Savaria Dealer installs and services the M2LIFT. Under no circumstances is anyone other than a dealer with Savaria training and authorization to install, adjust, service or modify any mechanical or electrical device on this equipment. Failure to follow this warning can result in safety system compromises or defeat; this can result in serious injury or death. Savaria accepts no liability for property damage, warranty claims or personal injury, including death, in this circumstance.

Passenger safety is the result of countless details in the equipment’s design, manufacture, and installation. After installation, reliable operation and continual safe operation requires regular service and inspection at least twice per year, or more frequently where usage, environment, or local jurisdiction requires. As the Owner, you are responsible for ensuring that regular service and inspections occur in a timely manner.

Refer to this manual for specifications, operating instructions and maintenance of the M2LIFT.

Upon completion of installation, the dealer must provide you with the following information and ensure it is recorded in this manual. In addition, either the dealer or you must keep any service and/or maintenance records in the Maintenance Record section of this manual.

WARRANTY

Ensure your Savaria Dealer provides you with a copy of the manufacturer’s limited parts warranty and documentation relating to any Dealer labour warranty.

FOR OWNER’S RECORDS

Customer Name: _____

Installing Dealer: _____

Dealer’s Telephone Number: _____

Date Installed: _____

Serial/Job Number: _____

Table of Contents

TO ENSURE SAFE OPERATION	4
1. DESCRIPTION	5
2. GENERAL SPECIFICATIONS	6
3. OPERATION	7
Attendant Operation	7
Operating from the COP Controls	7
Operating from the Landing Station Controls	8
4. ADDITIONAL FEATURES	9
Safety Underpan	9
Gate Lock	10
Safety Brake	10
Emergency Stop Button	10
Battery Lowering	10
5. MAINTENANCE	11
Maintenance Schedule	12
Maintenance Record	13
Operator Troubleshooting	14

TO ENSURE SAFE OPERATION

To ensure safe operation of this equipment, pay careful attention to the important notes below.

- Read this manual carefully before using the equipment.
- To prevent accidents, adhere strictly to the instructions and keep clear of moving parts at all times.
- Follow instructions on all equipment labels at all times. Replace any damaged labels immediately.
- Ensure that only qualified personnel perform maintenance and service on the unit.
- When replacing parts, be sure that only genuine Savaria parts are used.
- This unit is intended for use by a mature person who understands its proper operation as set out in this manual.
- Prior to operation, make sure that:
 - All doors and gates are locked and secure.
 - All areas in and around the lift are clear of any obstructions.
 - All lights are functioning properly.
- Test your keys and emergency stop button every month.

1. DESCRIPTION

Figure 1 shows the exterior components of the M2LIFT.

Figure 1

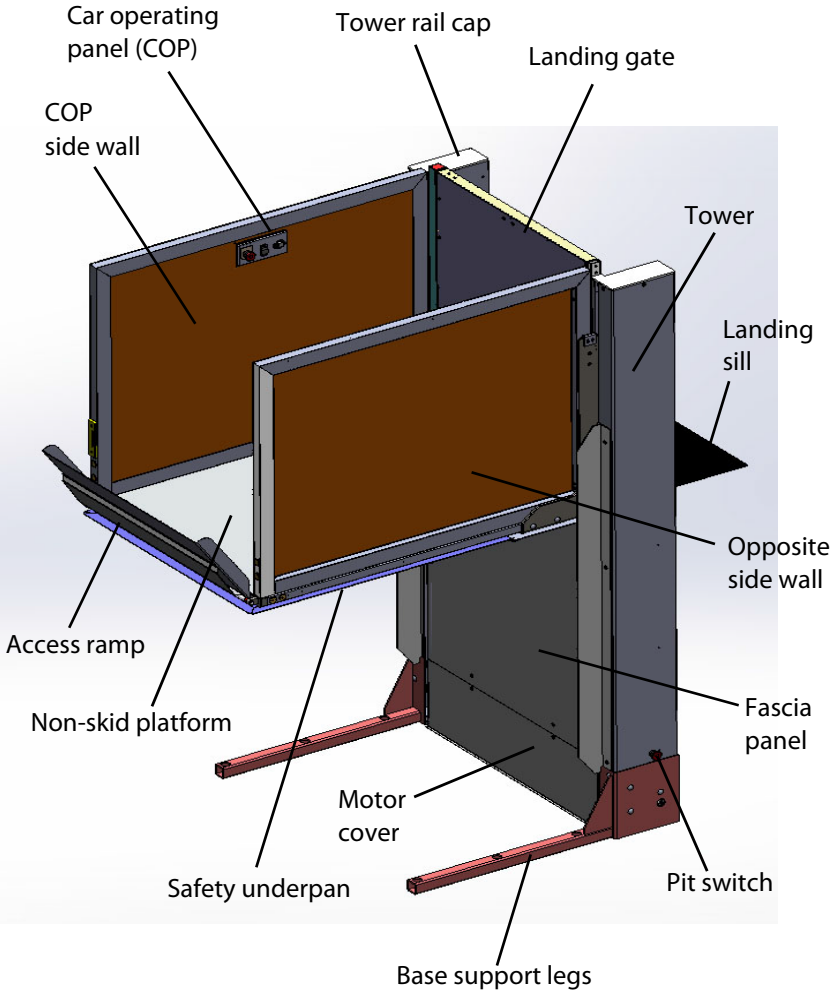

2. GENERAL SPECIFICATIONS

Load capacity	750 lb (340 kg)
Maximum travel	M2LIFT-40: 42" (1067 mm) M2LIFT-60: 62" (1575 mm) M2LIFT-75: 77" (1956 mm)
Minimum travel	15.5" (394 mm)
Levels serviced	2
Travel speed	9 ft/min (0.046 m/s)
Daily cycle	Normal: 10 Heavy: 25 Excessive: 40 Maximum starts in 1 hour on standard installation: 5
Platform size	37 1/8" x 54 1/8" (9443 mm x 1375 mm)
Side wall height	42" (1067 mm)
Access	Front/rear access (type 2 cab)
Power supply	120 VAC, 15A, 60 Hz, single phase
Drive system	Direct drive gear Chain suspension
Motor	24 VDC, 1.3 HP, geared
Controller	LUT125 PCB
Finish	Electrostatic powder coat paint on all metallic surfaces and vacuumed formed plastics
Standard features	24VDC operation Wireless call/send stations at landings Constant-pressure type buttons Operating control buttons on platform Automatic battery recharging system (115 VAC) Low-voltage controls Limit switches Non-skid platform surface Automatic access ramp Emergency stop button (E-stop on COP) and alarm Pit switch (E-stop on tower) Safety underpan Motor safety brake Battery lowering Outdoor package

3. OPERATION

Attendant Operation

- The attendant shall only operate the lift from the call station located at the lower landing if the lift is unenclosed.
- The attendant shall have full view of the floor area under the lift and of the rider at all times.
- If the lift is enclosed, the lift can be operated from the upper landing provided the operator has a view of the rider at all times.
- During attendant operation, the car directional controls must not be operational.

Operating from the COP Controls

Figure 2 shows the car operating panel (COP).

Figure 2

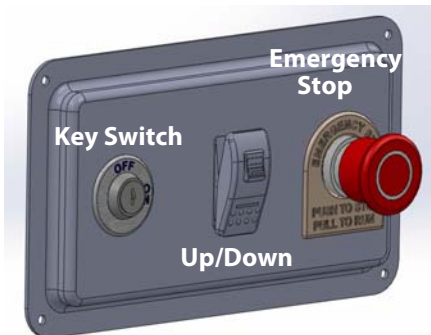

To operate the lift from the COP controls:

- 1** Insert the key into the key switch and turn it to the ON position to activate the operating buttons.
- 2** Apply constant pressure on the Up/Down button (as required) to move the platform to the desired landing. Note that the lift will not move if the gate is open.
- 3** When the lift reaches the landing, the gate will unlock automatically. If you need to re-open the door after a delay, turn the key to the ON position and press the call button again to unlock the gate.
- 4** To prevent unauthorized use of the lift, take the key out when the unit is not in operation.

- 5 Pressing the Emergency Stop button during travel will stop the lift immediately and activate the alarm. The Emergency Stop overrides the landing station controls. Pull the Emergency Stop out to return the lift to normal operation.
- 6 If the gate is locked at a landing for more than 10 seconds, you can press the Up button to unlock the gate.

Operating from the Landing Station Controls

Figure 3 shows the different types of landing stations (hall calls).

Figure 3

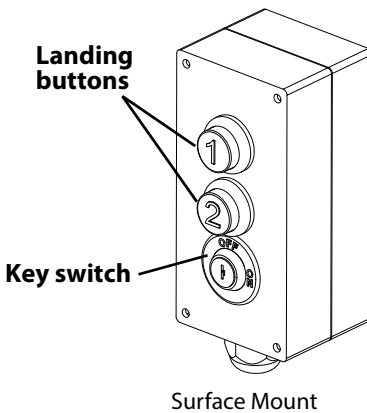

To operate the lift from the landing (call/send) station controls:

- 1 Insert the key into the key switch and turn it to the ON position to activate the operating buttons.
- 2 Press the appropriate landing button to move the platform to the desired landing. Note that the lift will not move if the gate is open.
- 3 When the lift reaches the landing, the door will unlock automatically. If you need to re-open the door after the delay, turn the key on and press the call Up button again to unlock the door.
- 4 To prevent unauthorized use of the lift, take the key out when the unit is not in operation.

4. ADDITIONAL FEATURES

Safety Underpan

The safety underpan (shown in Figure 4) is located under the platform. The underpan has sensors that detect any obstacles and stop the downward travel of the lift. This is optional on enclosed units and required on open hoistways.

Figure 4

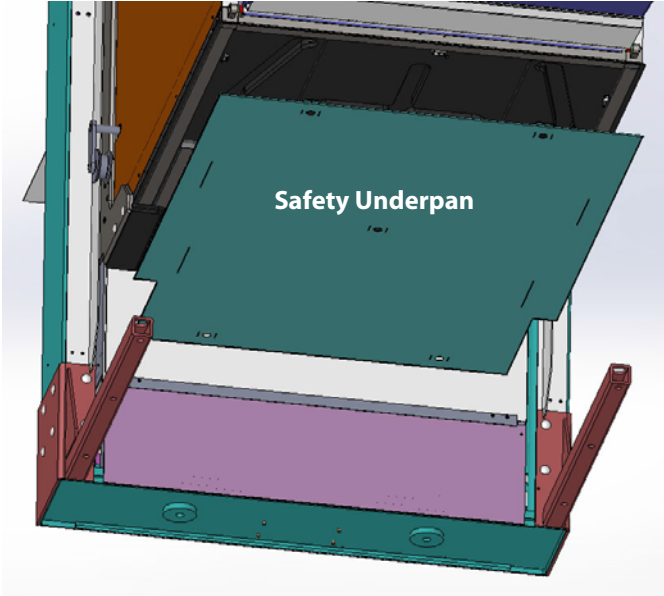

Gate Locks

The WR-500 gate lock keeps the gate locked when the platform is moving and not at a landing.

NOTE

Keys are for emergency use only and should always be kept in a safe place for use by trained personnel only. After use of any emergency function (access key or manual lowering device), ensure that all doors/gates are secure and locked. While the emergency function is in use, DO not leave the area unattended.

Emergency Gate Opening

The gate can be opened manually using the emergency key provided for the WR-500 lock (Figure 5).

Insert the key into the lock and turn it a half turn clockwise to unlock the gate. Pull the gate open and then turn the key a half turn counter-clockwise to remove it from the lock. **DO NOT** open the gate if there is any chance of falling from the platform.

Safety Brake

The motor **Safety Brake** stops the platform in the event of a chain failure.

During normal operation, the chain tension keeps the brake mechanism up so the brake cam does not interfere with the tower guide rail. If a chain failure occurs, the brake mechanism activates and stops the platform.

Emergency Stop Button

Pressing the red **Emergency Stop** button during travel will stop the lift immediately and activate the alarm. The Emergency Stop overrides the landing (call/send) stations. Be sure to pull the Emergency Stop button out to return the lift to normal operation.

Battery Lowering

In the event of a power failure, press the DOWN button to bring the lift to the lower level.

Figure 5

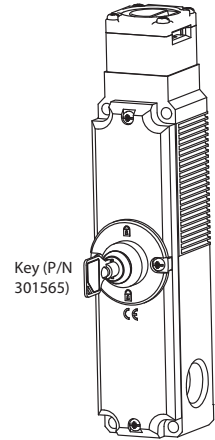

5. MAINTENANCE

NOTE

The owner can perform the 2-month inspections, but the 6-month inspections **must** be performed by a Qualified Technician. Contact your Authorized Dealer to schedule maintenance.

Note that units installed in adverse environments will require additional maintenance on a monthly basis.



DANGER

Technicians must always use the shoring pin when working under the lift (see below for pin location).

Figure 6

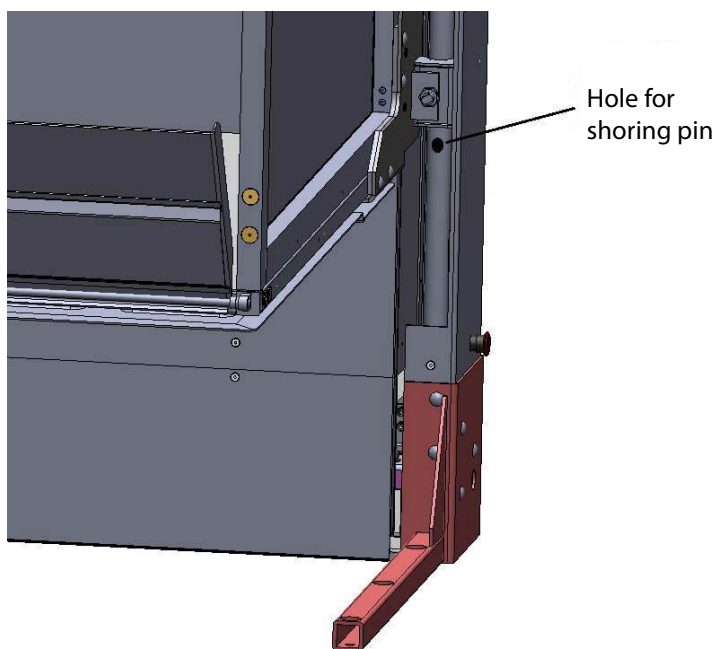

Maintenance Schedule

Verification by owner	Frequency
Verify general operation of the lift	Every 2 months
Verify correct operation of the safety devices: <ul style="list-style-type: none"> • Underpan sensors • Emergency stop • Gate lock (the lift should not run unless the gate is closed and locked) 	Every 2 months
Verification by technician ONLY	Frequency
Verify the following: <ul style="list-style-type: none"> • General operation of the lift • Operation of the underpan sensors • Operation of the emergency stop • Operation of the gate lock contacts. The lift should not run unless the gate is closed and locked. 	Every 6 months
Check the suspension system: <ul style="list-style-type: none"> • Chains • Connecting links • Chain pulleys and shafts • Parts holding the chains on the roller supports • Chain tensioners on the rail (they should be tight) 	Every 6 months
Verify that all hardware is tightened.	Every 6 months
Check the safety brake.	Every 6 months
Check the rollers (function and wear).	Every 6 months
Ensure that all filler panels are securely fastened in the gate.	Every 6 months

Maintenance Record

Date	Time	Reason for Call	Comments	Dealer

Operator Troubleshooting

The following table lists potential problems and their possible solutions.

If the problem persists, contact your Authorized Dealer.

Potential Problem	Possible Solution
Platform goes up but does not come down	Check the underpan sensors. Pull down on the underpan to ensure the pan is not stuck in the activated position.
Platform comes down but does not go up	Check that the power cord is plugged in.
Platform does not move	<p>Check that the key is ON.</p> <p>Check that the gate is closed.</p> <p>Check to see if the Emergency Stop buttons (on the COP and tower) are pushed in; they must be pulled out for normal operation.</p> <p>If the platform is at the top landing, check the underpan sensors as described above.</p> <p>Check that the power cord is plugged in.</p>

Authorized Savaria Dealer

M2LIFT OWNER'S MANUAL

Part No. 001103
Copyright © 2019

Savaria Concord Lifts, Inc.
2 Walker Drive
Brampton, Ontario, L6T 5E1, Canada
www.savaria.com

For service or questions about this product, please contact your installing dealer.

DEALER NAME: _____

DEALER PHONE: _____

